

Liquid Flow Switch

DESCRIPTION

Waterproof liquid flow switches.

APPLICATION

Control and monitor liquid flow of boilers, pumps, etc., of heating, cooling, and air conditioning equipment.

FEATURES

- Flow control of water and normal media
- Renovated SPDT micro switch ensures the reliable switch function
- 15(8A) 250VAC switch rating
- IP65, class 1 enclosure
- Setpoint adjustable
- Stainless steel paddle
- Brass material
- Max. liquid temp 120°C
- Max working pressure 13.5Bar

SPECIFICATIONS

Type of operation	On/Off, single-stage, micro switch
Output	SPDT 15(8A) 24/250VAC
Flow rates	See flow rate table
Flow rate setting adjustment	Internal screw
Sensing element	Paddle
Liquid applications	Hot, chilled, well, pool and sea water, Brine or ethylene glycol
Parts material in contact with fluid	Brass
Paddle material	Stainless steel
Liquid temperature	-20°C~120°C
Permissible ambient temperature	-40°C~85°C
Permissible ambient humidity	10...90% RH, non-condensing
Cable entry	M18 Fitting
Housing	Fire Resistance ABS or PC
Protection	IP65
Color	White
Weight	1.0Kg



certified
ISO9001 **CE**

TYPES OF MODEL

MODEL	CONNECTION
KWFS-1	1/2"-14NPT
KWFS-2	3/4"-14NPT
KWFS-3	1"-11 1/2 NPT

PADDLES

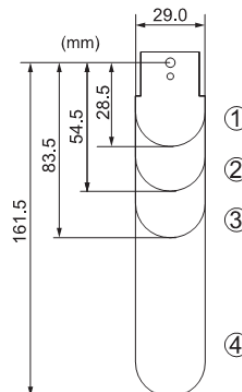

Install Paddle	
Pipe	No.
1"	1
1 1/4"	1
1 1/2"	1
2"	1,2
2 1/2"	1,2
3"	1,2,3
4"	1,2,3
4"Z	1,2,3,4
5"	1,2,3
5"Z	1,2,3,4
6"	1,2,3
6"Z	1,2,3,4
8"	1,2,3
8"Z	1,2,3,4

Liquid Flow Switch

LIQUID FLOW RATE TABLE

GPM (m³/hr) required to actuate switch

Line pipe size (in.)		1	1-1/4	1-1/2	2	2-1/2	3	4	4Z	5	5Z	6	6Z	8	8Z
Min. flow	Flow increase ① & ② Connected	4.2 (1.0)	5.8 (1.3)	7.5 (1.7)	13.7 (3.1)	17.6 (4.0)	27.5 (6.2)	64.7 (14.7)	35.2 (8.0)	12.50 (28.4)	57.01 (12.9)	90.0 (43.1)	74.0 (16.8)	374.7 (85.1)	204.7 (46.5)
	Flow Decrease ① & ③ Connected	2.5 (0.6)	3.7 (0.8)	5.0 (1.1)	13.7 (2.2)	11.9 (2.7)	19 (4.3)	50.1 (11.4)	26.9 (6.1)	101.0 (22.9)	41.0 (9.3)	158.0 (35.9)	54.0 (12.3)	319.7 (72.6)	170.0 (38.6)
Max. flow	Flow increase ① & ② Connected	9.2 (2.1)	13.3 (3.0)	17.6 (4.0)	26.9 (6.1)	30.8 (7.0)	50.2 (11.4)	127.6 (29.0)	81.0 (18.4)	245.0 (55.6)	118.0 (18.4)	374.7 (85.1)	144.0 (32.7)	759.5 (172.5)	415.0 (94.2)
	Flow Decrease ① & ③ Connected	8.1 (1.9)	12.5 (2.8)	16.3 (3.7)	25.1 (5.7)	28.6 (6.5)	47.1 (10.7)	122.0 (27.7)	76.2 (17.3)	234.7 (53.3)	111.0 (25.2)	359.7 (81.7)	134.7 (30.6)	729.6 (165.7)	400.6 (90.8)

Note: For flow rates with suffix "Z", the 6 inch paddle must be installed.

ELECTRICAL WIRING

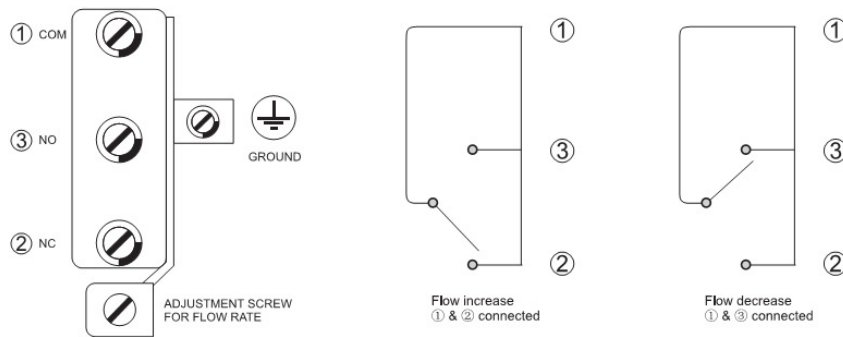

INSTALLATION

The flow switch can be installed in every position far from elbows or throttlings, with arrow on flow direction. If pipe is vertical, recalibrate range to balance paddle weight. If the device is downwards mounted, take care to slugs and apply it in a straight pipe that is far from filters, valves, etc., with length at least 5 times the diameter of pipe upstream and downstream the unit.

NOTE

The flowswitch is factory calibrated at its minimum sensitivity. To increase the set valve, turn the adjustment screw clockwise. The cut-off valve must be \geq the minimum flow necessary to guarantee the protection of the plant.

DIMENSIONS (mm)

